

SR598ML3E



Mounting Pattern
Up to 800 x 600mm
(31.49" x 23.62")



Max Load
280lb
(127kg)

SMARTMOUNT.

Motorized Height Adjustable Flat Panel Cart

FOR 55" TO 86" INTERACTIVE DISPLAYS

The Motorized Height Adjustable Cart was designed to safely mount, move, and store an interactive display. UL recognized actuators allow you to raise or lower a display, up to 25.6" (650mm), with the touch of a button. For easy setup and storage, the rear shelf provides room for a mini PC and power strip, while the power cord can be neatly bundled and stored just below. The cart's large wall plate and locking casters provide a stable foundation for touch applications, and allow you to easily maneuver the cart from room to room. The durable black powder coat finish provides a nice aesthetic to complement this highly functional solution that is ideal for any touchscreen application.

- Display height can be adjusted up to 25.6" (650mm) with the touch of a button
- Maneuvers easily on 4" (102mm) swivel casters, two locking
- Pre-assembled base and casters provides rigidity, stability and quick assembly
- Textured black powder coat finish helps hide finger prints and dust
- Display adaptor fits from 200 x 200 to 800 x 600mm mounting patterns
- Safety limit switch automatically reverses direction and stops when a collision is detected in an upward, downward or lateral force



REAR STORAGE

Provides up to 29"W x 13.5"H x 4"D storage for mini PCs such as Dell Optiplex Micro, HP 260 G2, Lenovo M600 Tiny or Intel NUC

VERTICAL ADJUSTMENT

Center of display is adjustable from 34"-60" from the floor

WELDED BASE AND PRE-ASSEMBLED CASTERS

Provides rigidity, stability and quick assembly

SAFE AND EASY MANEUVERABILITY

4" (102mm) swivel casters meet UL/CUL requirements



Rear Shelf, shown with optional accessories - Rear Laptop Shelf, 6 Outlet Surge Protector and Power Cord Manager



RoHS
2002/95/EC



Complies with the ADA Standards for Accessible Design, Section 308.

info@peerless-av.com

peerless-av.com

peerless-AV[®]
Driving Technology Through Innovation

SR598ML3E SmartMount® Motorized Height Adjustable Flat Panel Cart for 55" to 86" Interactive Displays

Product Specifications

	DIMENSIONS (W X H X D)	PRODUCT WEIGHT	LOAD CAPACITY	FINISH	AVAILABLE COLORS
SR598ML3E	45.76" x 72.47" x 28.75" (1162 x 1841 x 730mm)	100lb (45.4kg)	280lb (127kg) Display	Textured Powder Coat	Black

Package Specifications

	PACKAGE SIZE (W x H x D)	PACKAGE SHIP WEIGHT	PACKAGE UPC CODE	PACKAGE CONTENTS	UNITS IN PACKAGE
SR598ML3E	48.00" x 10.00" x 39.00" (1219 x 254 x 991mm)	130.5lb (59.2kg)	735029326182	Assembled Base with Motorized Columns and Casters, Universal Display Adaptor, Control Box, Control Switch, Hardware & Instructions	1

Accessories

- ACC-ML3ELS: Rear Laptop Shelf
- ACC-ML3ECW: Power Cord Manager
- ACC-WMVCS: Video Conferencing Shelf
- PVP1200-CPL6: 6 Outlet Surge Protector
- ACC-MCCM: Component Mount

All dimensions = inch (mm)

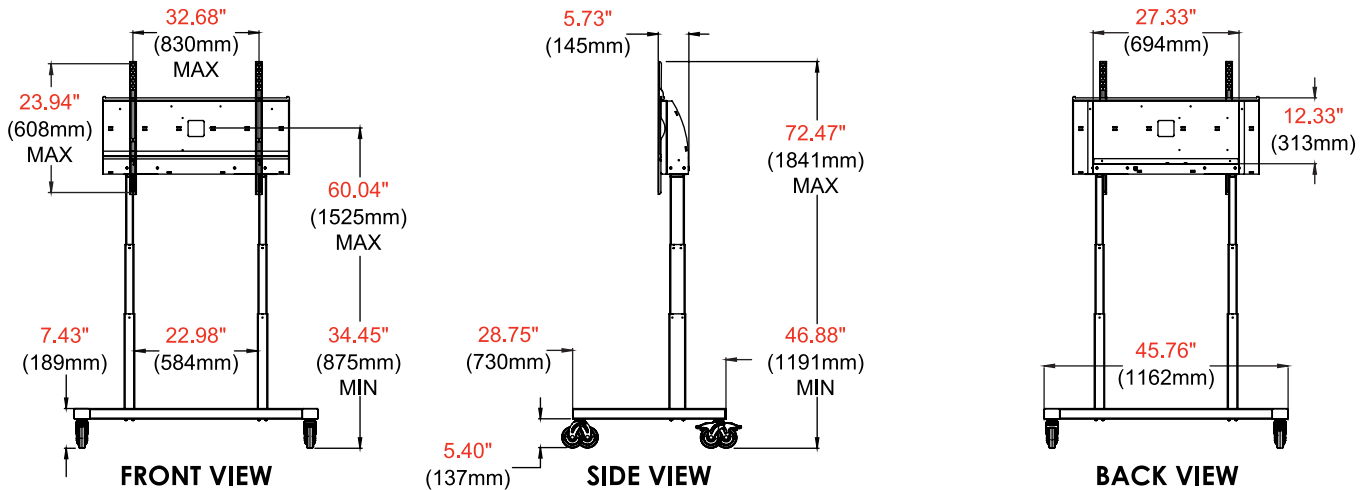

Architect Specifications

The SmartMount® Motorized Height Adjustable Flat Panel Cart shall be a Peerless-AV model SR598ML3E and shall be located where indicated on the plans.. Assembly and installation shall be done according to instructions provided by the manufacturer.

Visit peerless-av.com to see the complete line of AV solutions from Peerless-AV, including outdoor displays, kiosks, display mounts, projector mounts, carts/stands, and a full assortment of accessories.

Peerless-AV
2300 White Oak Circle
Aurora, IL 60502
USA
(800) 865-2112
(630) 375-5100

Peerless-AV EMEA
Unit 2 Curo Park
Frogmore, St. Albans
Hertfordshire, AL2 2DD
United Kingdom
+44 (0) 1923 200 100

Peerless-AV B.V.
Papendorpseweg 75
3528 BJ Utrecht
The Netherlands
+31 (0) 70 770 8037

Peerless-AV Latin America
Av. de las Industrias 413
Parque Industrial Escobedo
General Escobedo, N.L.,
México, 66062
+52 (81) 8384-8300

